

ABLUE TECHNOLOGY

PTR9818

*Full Bluetooth 5 ready multi-protocol SoC Module
Embedded Cortex™ M4F 32 bit processor
Support Bluetooth 5, Zigbee, Thread, MESH, ANT
Ideal choice of IoT and Smart product*

The PTR9818 ultra-low power Bluetooth 5 ready multiprotocol System on Module based on the nRF52840 from Nordic Semiconductor. The module can support Bluetooth 5.2 by upgrading the protocol stack. The module with an ARM® Cortex™ M4F 32 bit processor, 1MB Flash/256KB RAM, embedded 2.4GHz transceiver, and integrated antenna, provide a complete solution with no additional RF design, Bluetooth 5, ANT/ANT+, 802.15.4 and 2.4GHz proprietary multiprotocol support, allowing faster time to market, while simplifying designs, reducing BOM costs, also reduce the burden of Regulatory approvals to enter the world market. Making you more quickly into the Bluetooth smart application and remove the worries.

It has an ARM® TrustZone® CryptoCell-310 co-processor for implementation of IoT security.

Features

- | | |
|--|--|
| <ul style="list-style-type: none">◆ Nordic nRF52840 with ARM Cortex M4F◆ Multiprotocol support :
Bluetooth 5, ANT/ANT+, and 2.4GHz proprietary, 802.15.4 Thread and Zigbee, .◆ Bluetooth 5: 2 Mbps, 1 Mbps, 500 kbps, 125 kbps◆ IEEE 802.15.4-2006: 250 kbps◆ Proprietary 2.4 GHz: 2 Mbps, 1 Mbps◆ Integrated DC-DC converter◆ Serial Wire Debug (SWD)◆ Nordic SoftDevice Ready◆ Over-the-Air (OTA) firmware update◆ Flash/RAM: 1MB/256KB.◆ 46 General purpose I/O pins◆ 15 level low-power comparator with wake-up from System OFF mode◆ Two 2-wire Master/Slave (I2C compatible)◆ I2S audio interface | <ul style="list-style-type: none">◆ 12 bit/200KSPS ADC◆ 1 QSPI (32Mbps)◆ 4 SPI Master/ 3 SPI Slave (8Mbps)◆ 2 UART (with CTS/RTS and DMA)◆ 4x 4-channel PWM unit with EasyDMA◆ USB 2.0 full speed (12 Mbps) controller◆ 20 channel CPU independent Programmable Peripheral Interconnect (PPI).◆ Quadrature Demodulator (QDEC)◆ 128-bit AES HW encryption◆ 5 x 32 bits, 3 x 24 bits Real Time Counters (RTC)◆ NFC-A tag interface for OOB pairing◆ TX power: +8dBm to-20dBm in 4 dB steps.◆ Sizes: 22.7x17.5 x1.8mm with Antenna◆ Integrated high performance PCB antenna◆ DC/DC on board◆ No external components required◆ Operation voltage: 1.7V to 5.5V |
|--|--|

ABLUE TECHNOLOGY

Typical Applications:

- - 2.4 GHz Bluetooth low energy systems
- - Proprietary 2.4 GHz systems
- - Sports and leisure equipment
- - Mobile phone accessories, Connected Appliances
- - Health Care and Medical
- - Consumer Electronics, Game pads
- - Human Interface Devices, Remote control
- - Building environment control / monitoring
- - RFID, Security Applications, Low-Power Sensors
- - Bluetooth Low Energy GateWay
- - iBeacons™, Eddystone™, Indoor navigation
- - Lighting Products
- - Fitness devices, Wearables

Quick Specifications:

Multi-protocol	
Version	Bluetooth 5.0 and Higher/ANT/2.4GHz Proprietary/802.15.4/Zigbee
Security	AES-128
Radio	
Frequency	2.360GHz to 2.500GHz
Modulations	GFSK at 2/1 Mbps, Long range 125/500kbps, 802.15.4- 250 kbps
Transmit power	+8dBm to -20dBm in 4 dB steps.
Receiver sensitivity	-103dBm@BLE 125kbps(long range), -96dBm@BLE 1M
Antenna	Integrated PCB Antenna
Current Consumption	
TX only @ +8 dBm, @ 3V, DC/DC enabled	14.1 mA
TX only @ 0 dBm, @ 3V, DC/DC enabled	4.8 mA
RX only @ 1 Mbps @ 3V, DC/DC enabled	4.6 mA
CPU @ 64MHz from flash @ 3V, DC/DC	3.3 mA
System On	1.5 μ A
System Off	0.4 μ A
Operating conditions	
Power supply	1.7~5.5V
Operating temperature	-25~+85 °C

ABLUE TECHNOLOGY

Block diagram:

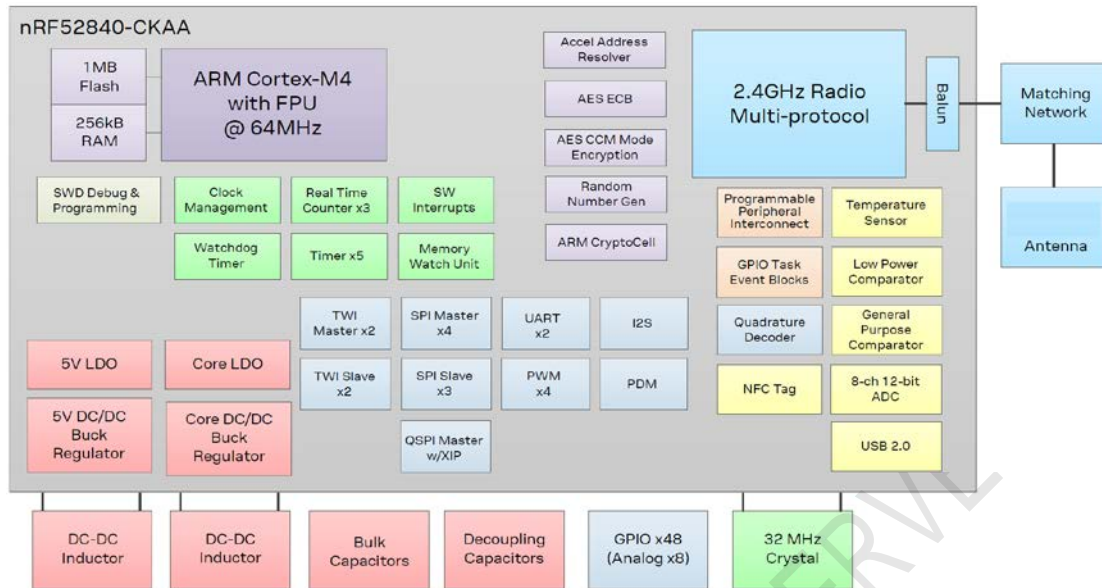

Pin Description of Module (Top View) :

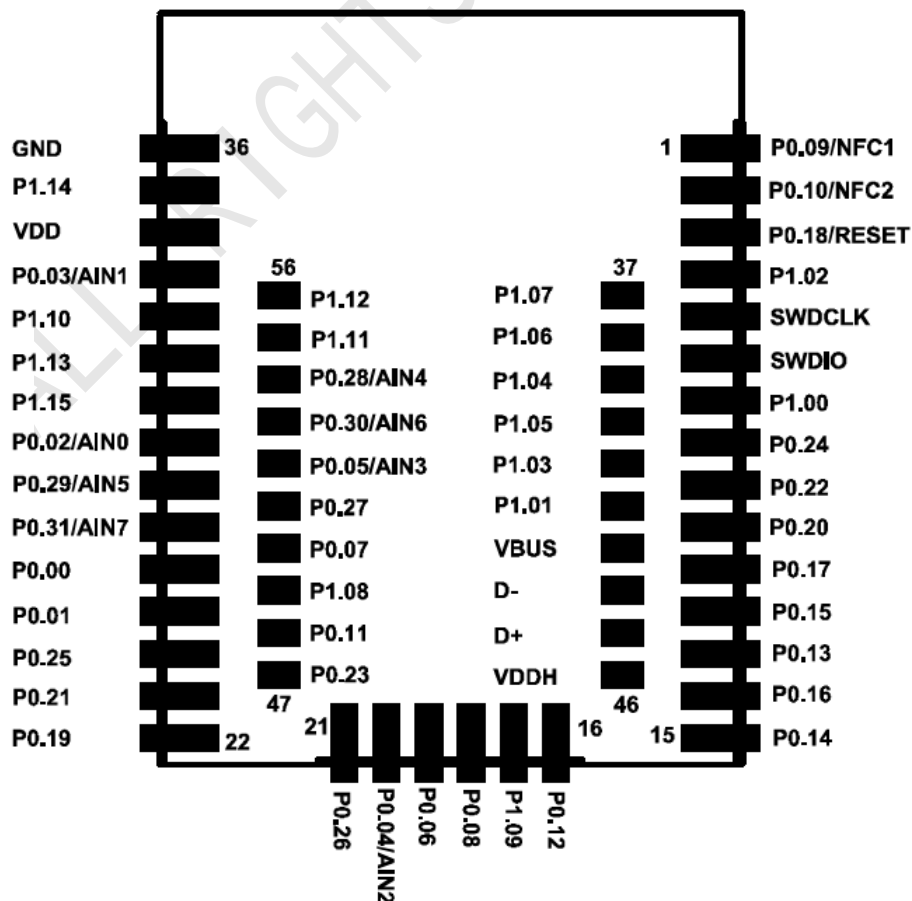

ABLUE TECHNOLOGY

Pin	Name	Description	Recommend usage
Pin1	P0.09/NFC1	Digital I/O/ NFC input	Standard drive, low frequency I/O
Pin2	P0.10/NFC2	Digital I/O/ NFC input	Standard drive, low frequency I/O
Pin3	P0.18/RESET	Digital I/O/RESET	QSPI/CSN/RESET
Pin4	P1.02	Digital I/O	
Pin5	SWDCLK	HW debug and programming	
Pin6	SWDIO	HW debug and programming	
Pin7	P1.00	Digital I/O	
Pin8	P0.24	Digital I/O	QSPI
Pin9	P0.22	Digital I/O	QSPI
Pin10	P0.20	Digital I/O	
Pin11	P0.17	Digital I/O	
Pin12	P0.15	Digital I/O	
Pin13	P0.13	Digital I/O	
Pin14	P0.16	Digital I/O	
Pin15	P0.14	Digital I/O	
Pin16	P0.12	Digital I/O	
Pin17	P1.09	Digital I/O	
Pin18	P0.08	Digital I/O	
Pin19	P0.06	Digital I/O	
Pin20	P0.04/AIN2	Digital I/O/Analog input 2	
Pin21	P0.26	Digital I/O	
Pin22	P0.19	Digital I/O	QSPI/SCK
Pin23	P0.21	Digital I/O	QSPI
Pin24	P0.25	Digital I/O	
Pin25	P0.01/XL2	Reserve for 32.768KHz use	
Pin26	P0.00/XL1	Reserve for 32.768KHz use	
Pin27	P0.31/AIN7	Digital I/O/Analog input 7	Standard drive, low frequency I/O
Pin28	P0.29/AIN5	Digital I/O/Analog input 5	Standard drive, low frequency I/O
Pin29	P0.02/AIN0	Digital I/O/Analog input 0	Standard drive, low frequency I/O
Pin30	P1.15	Digital I/O	Standard drive, low frequency I/O
Pin31	P1.13	Digital I/O	Standard drive, low frequency I/O
Pin32	P1.10	Digital I/O	Standard drive, low frequency I/O
Pin33	P0.03/AIN1	Digital I/O/Analog input 1	Standard drive, low frequency I/O
Pin34	VDD	Power Supply	
Pin35	P1.14	Digital I/O	
Pin36	GND	Ground	
Pin37	P1.07	Digital I/O	Standard drive, low frequency I/O
Pin38	P1.06	Digital I/O	Standard drive, low frequency I/O
Pin39	P1.04	Digital I/O	Standard drive, low frequency I/O
Pin40	P1.05	Digital I/O	Standard drive, low frequency I/O
Pin41	P1.03	Digital I/O	Standard drive, low frequency I/O
Pin42	P1.01	Digital I/O	Standard drive, low frequency I/O

ABLUE TECHNOLOGY

Pin43	VBUS	Power	5 V input for USB 3.3 V regulator
Pin44	D-	USB D-	USB
Pin45	D+	USB D+	USB
Pin46	VDDH	High voltage power supply	
Pin47	P0.23	Digital I/O	QSPI
Pin48	P0.11	Digital I/O	
Pin49	P1.08	Digital I/O	
Pin50	P0.07	Digital I/O	
Pin51	P0.27	Digital I/O	
Pin52	P0.05/AIN3	Digital I/O/Analog input 3	
Pin53	P0.30/AIN6	Digital I/O/Analog input 6	Standard drive, low frequency I/O
Pin54	P0.28/AIN4	Digital I/O/Analog input 4	Standard drive, low frequency I/O
Pin55	P1.11	Digital I/O	
Pin56	P1.12	Digital I/O	Standard drive, low frequency I/O

*Low frequency I/O is signals with a frequency up to 10 kHz

Note: An internal 4.7 μ F bulk capacitor has been included on the module. For those application that with heavy GPIO usage and/or current draw, it is good design practice to add additional bulk capacitance as required for your application.

General Purpose I/O:

Each GPIO can be accessed individually with the following user configurable features:

- Input/output direction
- Output drive strength
- Internal pull-up and pull-down resistors
- Wake-up from high or low level triggers on all pins
- Trigger interrupt on all pins
- All pins can be used by the PPI task/event system; the maximum number of pins that can be interfaced through the PPI at the same time is limited by the number of GPIOTE channels
- All pins can be individually configured to carry serial interface or quadrature demodulator signals

Hardware RESET:

There is on-chip power-on reset circuitry, But can still be used in external reset mode, in this case, GPIO pin P0.18 as an external hardware reset pin. In order to utilize P0.18 as a hardware reset, the UICR registers PSELRESET[0] and PSELRESET[1] must be set alike, to the value of 0x7FFFFFF12. When P0.18 is programmed as RESET, the internal pull-up is automatically enabled.

HW debug and flash programming of Module :

The Module support the two pin Serial Wire Debug (SWD) interface and offers flexible and powerful mechanism for non-intrusive debugging of program code. Breakpoints, single stepping, and

ABLUE TECHNOLOGY

instruction trace capture of code execution flow are part of this support.

Pin	Flash Program interface
SWDIO	Debug and flash programming I/O
SWDCLK	Debug and flash programming I/O

This is the hardware debug and flash programming of module, J-Link Lite support, please refer www.segger.com.

Power and Configuration:

The Module has two internal regulator stages that each contain an LDO and DCDC regulator. The first regulator, REG0, is fed by the VDDH pin and can accept a source voltage of 2.5 V to 5.5 V. The output of REG0 is connected to the VDD pin and the input of the second regulator stage REG1. REG1 supplies power to the module core and can accept an input source voltage of 1.7V to 3.6V. Depending on how the VDD and VDDH pins are connected, the module will operate in one of two modes: Normal/Low Voltage (LV) or High Voltage (HV). The voltage present on the VDD pin is always the GPIO high logic level voltage, regardless of power mode.

To enter LV Mode, the same source voltage is applied to both the VDD and VDDH pins causing REG0 to automatically shut down leaving only the REG1 stage active. To enter HV, the source voltage is only applied to VDDH causing the VDD pin to become an output source supplied by REG0.

Mode	Pin of Module	Name	Power Connection
Normal/Low Voltage (LV)	Pin 34	VDD	1.7V to 3.6V source in
	Pin 46	VDDH	Same source as VDD
High Voltage (HV)	Pin 34	VDD	1.8V to 3.3V supply out
	Pin 46	VDDH	2.5V to 5.5V source in

Important: In both LV and HV modes, the GPIO logic level voltage is determined by the VDD pin. In HV mode, all external devices that are connected to the Module's GPIO must either be powered by the module (from VDD) or use level translation.

REG0 can supply a maximum current of 25mA for the module and external circuits in System On Mode and 1 mA in System Off Mode. External circuits powered from VDD in HV mode should be limited to no more than 5 mA to ensure stability at all radio transmit power levels.

USB Power: The USB interface on the Module can be used when the module is in either Normal /Low Voltage (LV) or High Voltage (HV) mode. The Module USB PHY is powered by a dedicated, internal LDO regulator that is fed by the VBUS pin (Pin43). This means that applying power to only the VBUS pin will not power the rest of the module. In order for the USB PHY to operate, VBUS must be externally powered.

ABLUE TECHNOLOGY

Reference circuitry:

In this section there are 5 reference circuits to show how to design an application circuit with this module.

Reference Circuit configuration 1

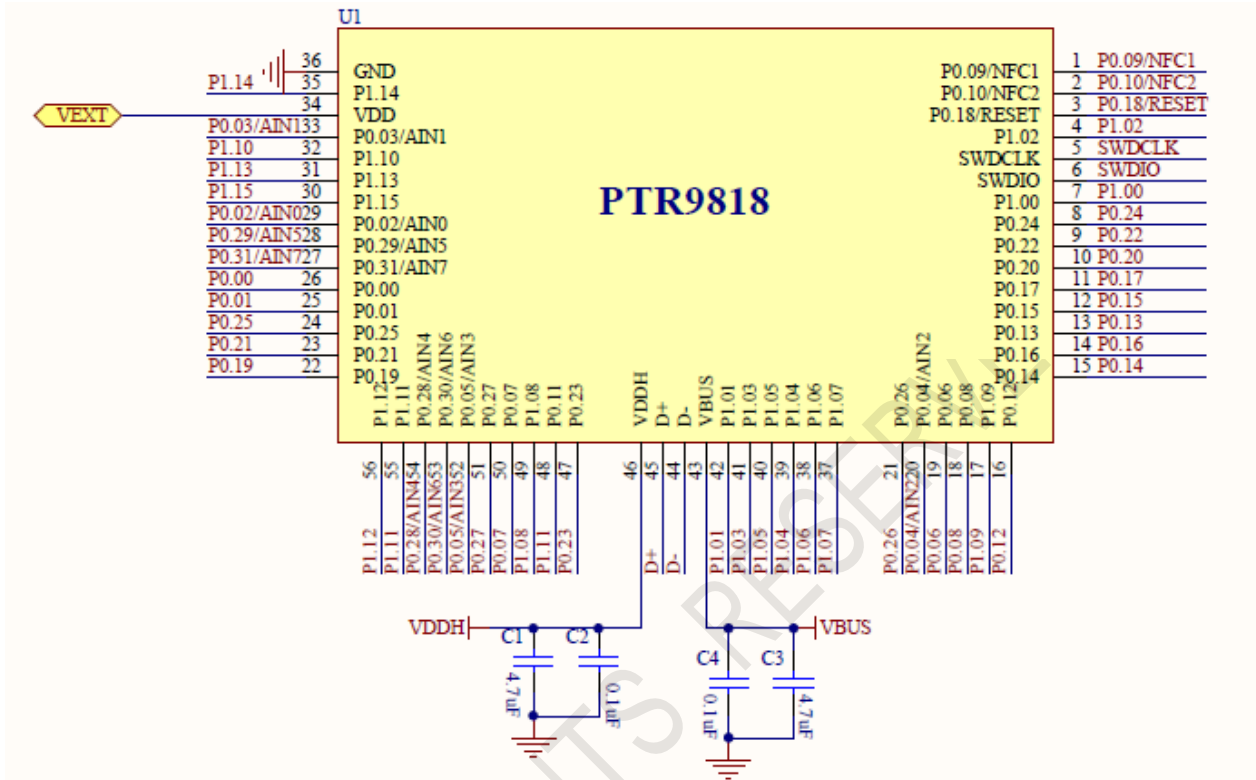

Configurations summary for reference circuit 1

Config no.	Main Supply		EXT Supply Output	USB
	VDDH	VDD		
Config.1	Battery/Ext.regulator	N/A	Yes	Yes

Explanation of symbols in reference circuit 1 schematic

Symbol	Parameter	Min.	Typ.	Max.	Units
V _{DDH}	Main supply voltage in high voltage mode	2.5	3.7	5.5	V
V _{BUS}	Supply voltage on VBUS pin	4.35	5	5.5	V
V _{EXT}	Voltage output on VDD when supplied from internal regulator (REG0). V _{DDH} is the input to REG0.	1.8		3.3	V

ABLUE TECHNOLOGY

Reference Circuit configuration 2

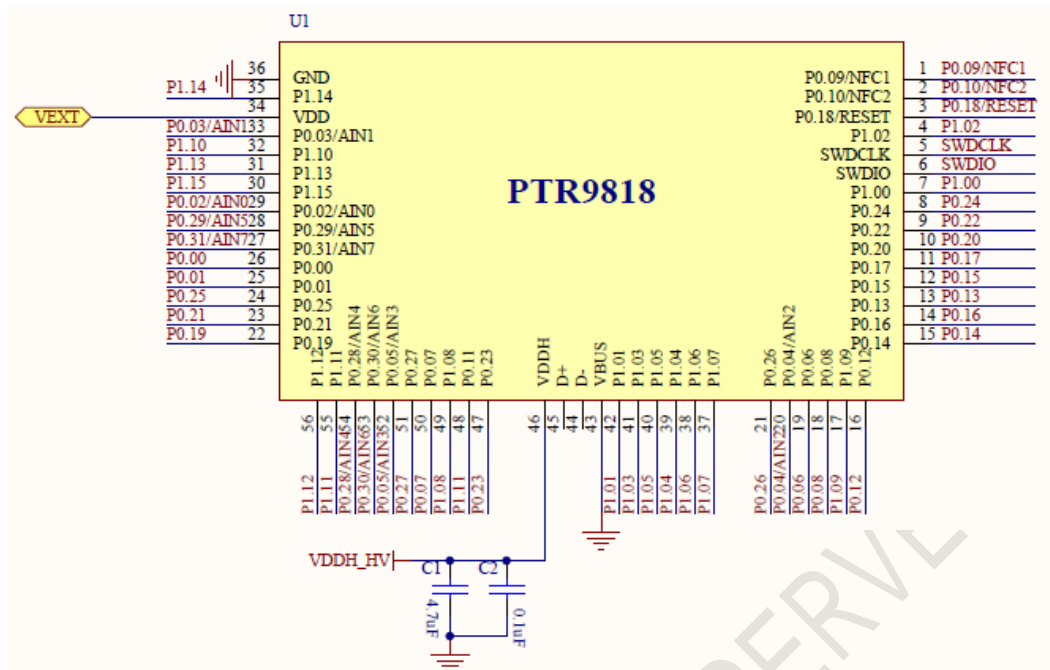

Configurations summary for reference circuit 2

Config no.	Main Supply		EXT Supply Output	USB
	VDDH	VDD		
Config.2	Battery/Ext.regulator	N/A	Yes	No

Explanation of symbols in reference circuit 2 schematic

Symbol	Parameter	Min.	Typ.	Max.	Units
V_{DDH}	Main supply voltage in high voltage mode	2.5	3.7	5.5	V
V_{EXT}	Voltage output on VDD when supplied from internal regulator (REG0). V_{DDH} is the input to REG0.	1.8		3.3	V

Reference Circuit configuration 3

ABLUE TECHNOLOGY

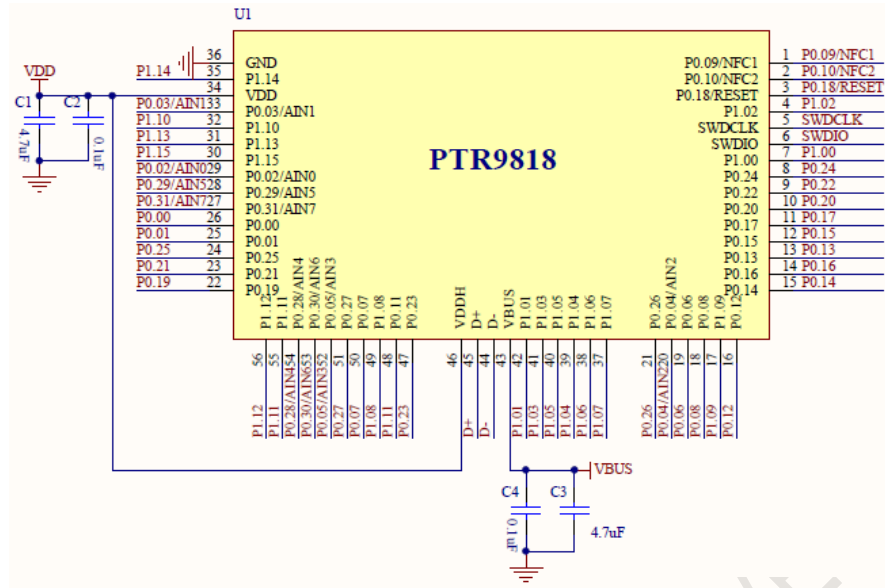

Configurations summary for reference circuit 3

Config no.	Main Supply		EXT Supply Output	USB
	VDDH	VDD		
Config.3	N/A	Battery/Ext.regulator	No	Yes

Explanation of symbols in reference circuit 3 schematic

Symbol	Parameter	Min.	Typ.	Max.	Units
V_{DD}	Main supply voltage in normal voltage mode	1.7	3	3.6	V
V_{BUS}	Supply voltage on VBUS pin	4.35	5	5.5	V

Reference Circuit configuration 4

ABLUETECHNOLOGY

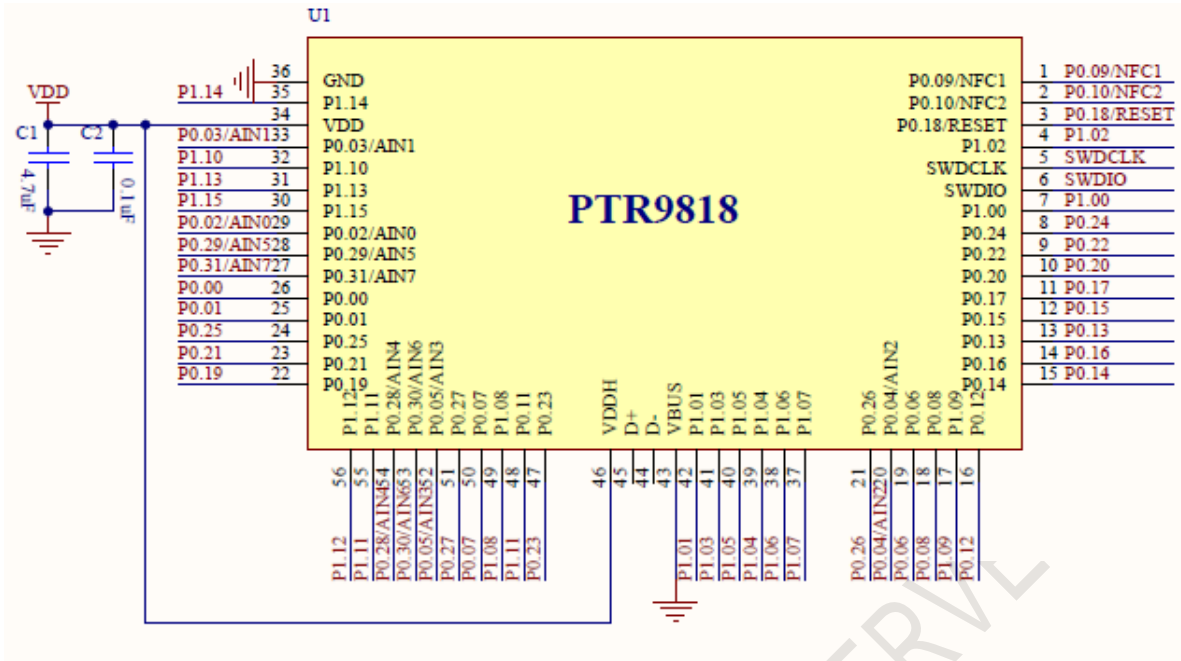

Configurations summary for reference circuit 4

Config no.	Main Supply		EXT Supply Output	USB
	VDDH	VDD		
Config.4	N/A	Battery/Ext.regulator	No	No

Explanation of symbols in reference circuit 4 schematic

Symbol	Parameter	Min.	Typ.	Max.	Units
V _{DD}	Main supply voltage in normal voltage mode	1.7	3	3.6	V

Reference Circuit configuration 5

ABLUE TECHNOLOGY

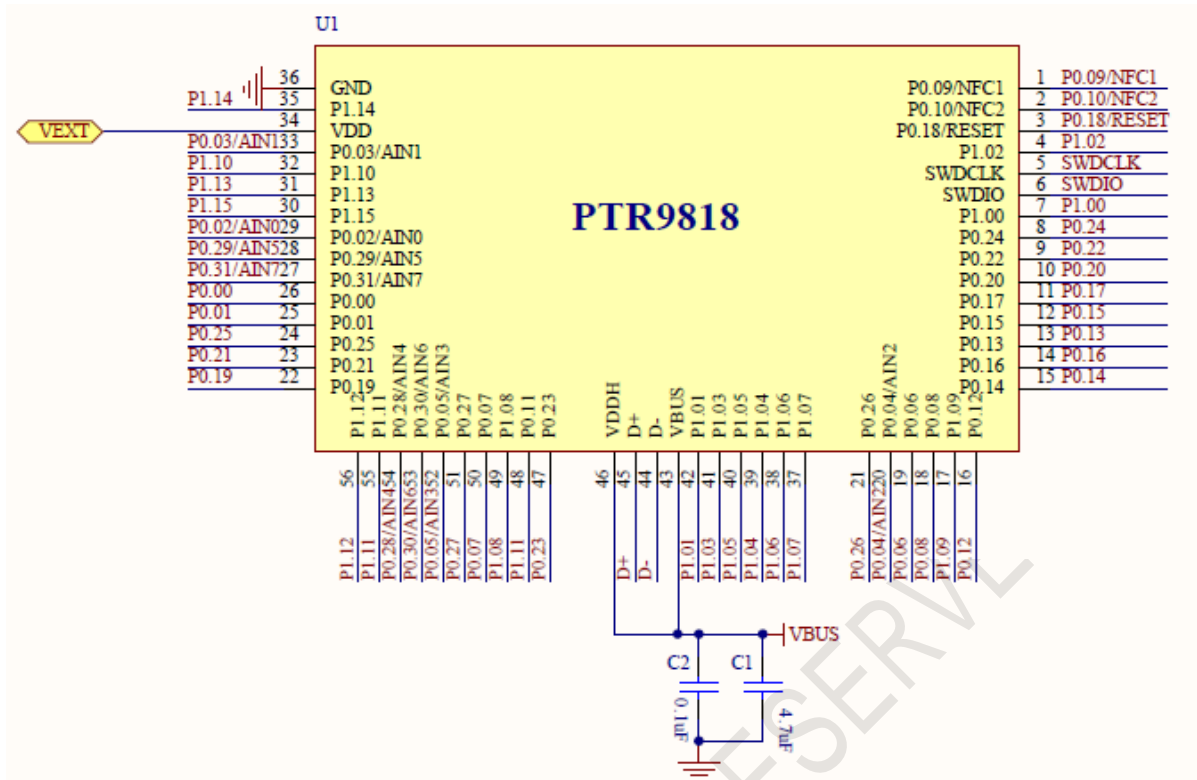

Configurations summary for reference circuit 5

Config no.	Main Supply		EXT Supply Output	USB
	VDDH	VDD		
Config.5	USB(VDDH = VBUS)	N/A	Yes	Yes

Explanation of symbols in reference circuit 5 schematic

Symbol	Parameter	Min.	Typ.	Max.	Units
V _{BUS}	Supply voltage on VBUS pin	4.35	5	5.5	V
V _{EXT}	Voltage output on VDD when supplied from internal regulator (REG0). V _{BUS} is the input to REG0.	1.8		3.3	V

Some general guidance is summarized here:

- Main supply voltage is connected to VDD/VDDH. The system will enter one of two supply voltage modes, normal or high voltage mode, depending on how the supply voltage is connected to these pins. Normal voltage mode is entered when the supply voltage is connected to both the VDD and VDDH pins (so that VDD equals VDDH). High voltage mode is entered when the supply voltage is only connected to the VDDH pin and the VDD pin is not connected to any voltage supply.
- By default, the LDO regulators in the chip are enabled and the DC/DC regulators are disabled. Registers DC/DCEN0 and DC/DCEN are used to independently enable the DC/DC regulators. External LC filters has been connected in the Module for DC/DC regulators being used.
- The GPIO high reference voltage always equals the level on the VDD pin. In normal voltage mode, the GPIO high level equals the voltage supplied to the VDD pin, and in high voltage mode it equals the level specified in the register REGOUT0 UICR registers.
- When the power is supplied to VDDH, the output from the VDD pin could be used to supply external circuitry. The feature must be configured in the EXTSUPLY and REGOUT0 UICR

ABLUE TECHNOLOGY

registers. In the reference circuitry, External supply is annotated with the VEXT net name.

- When using the USB peripheral, a 5V USB supply needs to be provided on the VBUS pin.

Recommended RF Layout & Ground Plane:

The module integrated antenna requires a suitable ground plane to radiate effectively. The area under and extending out from the antenna portion of the module should be kept clear of copper and other metal. The module should be placed at the edge of the PCB with the antenna edge facing out. Reducing the ground plane will reduce the effective radiated power. Please add as more as possible via holes on the mother board near the GND pin of module, this will be good for the RF performance of system board.

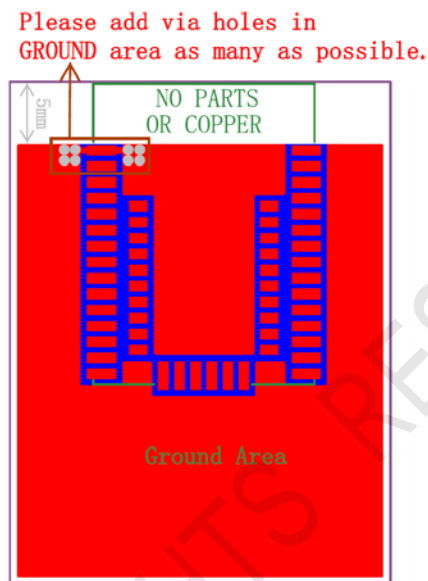

PCB Footprint (Top View) :

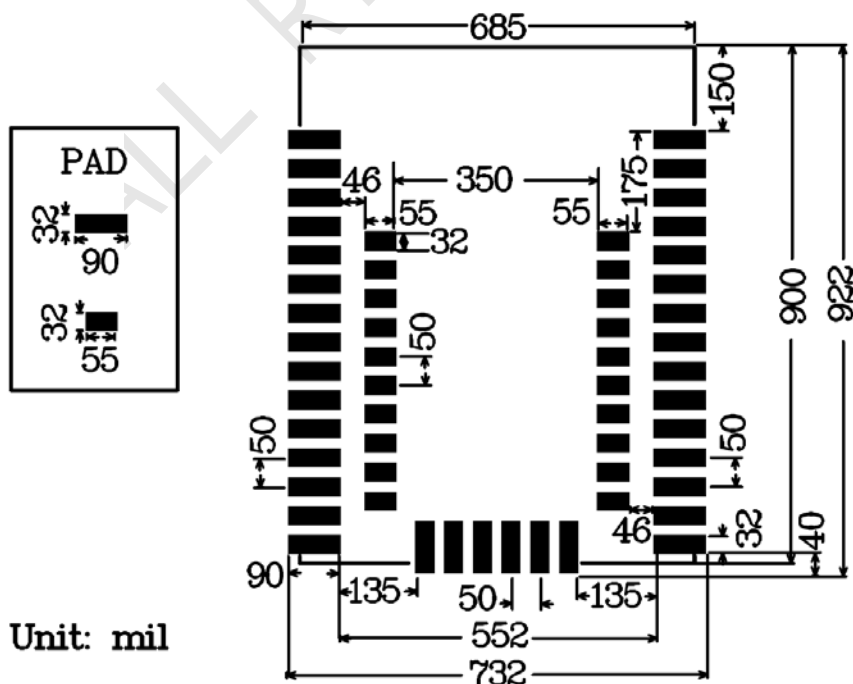

ABLUE TECHNOLOGY

Specifications:

Parameter	Min.	Typ.	Max.	Unit
Frequency Range	2402		2480	MHz
Maximum Output Power		+8		dBm
Rx Sensitivity Level, BLE1 Mbps		-96		dBm
Rx Sensitivity Level, BLE Long Range 125 kbps		-103		dBm
Data Rate on air	125		2000	kbps
Operating Temperature Range	-40	25	85	°C

Radio current consumption (transmitter):

Parameter	Min.	Typ.	Max.	Unit
TX only current (DC/DC, 3 V) PRF = +8 dBm		14.8		mA
TX only current (DC/DC, 3 V) PRF = +4 dBm		9.6		mA
TX only current (DC/DC, 3 V) PRF = +0 dBm		4.8		mA
TX only current (DC/DC, 3 V) PRF = -4 dBm		3.8		mA
TX only current (DC/DC, 3 V) PRF = -8 dBm		3.3		mA
TX only current (DC/DC, 3 V) PRF = -20 dBm		2.7		mA

Radio current consumption (Receiver):

Parameter	Min.	Typ.	Max.	Unit
RX only current (DC/DC, 3 V) 1 Mbps BLE		4.6		mA
RX only current (DC/DC, 3 V) 2 Mbps BLE		5.2		mA

Operating Conditions:

Parameter	Min.	Typ.	Max.	Unit
Supply voltages				
VDD	1.7	3.0	+3.6	V
VDDH	2.5	3.7	+5.5	V
VBUS	4.35	5	+5.5	V
Operating Temperature Range	-40	25	85	°C

Absolute Maximum Ratings:

Parameter	Min.	Max.	Unit
Supply voltages			
VDD	-0.3	+3.9	V
VDDH	-0.3	+5.8	V
VBUS	-0.3	+5.8	V
VSS	0	0	V
I/O pin voltage			

ABLUE TECHNOLOGY

Voltage on GPIO pins ($V_{cc} \leq 3.6V$)	-0.3	VDD + 0.3	
Voltage on GPIO pins ($V_{cc} > 3.6V$)	-0.3	+3.9	
NFC antenna pin current		80	mA
RF input level		10	dBm
Environmental			
ESD Human Body Model		2	KV
ESD Human Body Model Class		3A	
ESD Charged Device Model		500	V
Storage temperature	-40	125	°C
Flash memory Endurance		10000	Write/erase cycles

Note: Exceeding one or more of the limiting values may cause permanent damage to the module.

Notes and Cautions:

Design Notes

- (1) It is critical to following the recommendations of this document to ensure the module meets the specifications.
- (2) Power supply must be free of AC ripple voltage. If such noise is present, it is critical to provide proper filtering and decoupling.
- (3) The module should not be stressed mechanically after installation.
- (4) Exposing the module to significant temperatures will result in degradation and decreased lifetime.
- (5) Keep module away from other high frequency devices which may interfere with operation such as other transmitters and devices generating high frequencies.
- (6) Avoid static electricity, ESD and high voltage as these may damage the module.

Handling and Storage

- (1) Keep module away from other high frequency devices which may interfere with operation such as other transmitters and devices generating high frequencies.
- (2) Do not expose the module to the following conditions: Corrosive gasses such as Cl₂, H₂S, NH₃, SO₂, or NO_x Extreme humidity or salty air Prolonged exposure to direct Sunlight Temperatures beyond those specified for storage.
- (3) Do not apply mechanical stress.
- (4) Do not drop or shock the module.
- (5) Avoid static electricity, ESD and high voltage as these may damage the module.

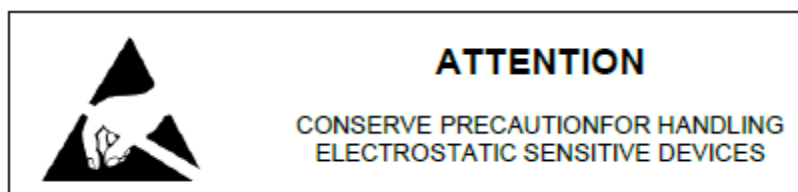

ABLUE TECHNOLOGY

Moisture Sensitivity

All plastic packages absorb moisture. During typical solder reflow operations when SMDs are mounted onto a PCB, the entire PCB and device population are exposed to a rapid change in ambient temperature. Any absorbed moisture is quickly turned into superheated steam. This sudden change in vapor pressure can cause the package to swell. If the pressure exerted exceeds the flexural strength of the plastic mold compound, then it is possible to crack the package. Even if the package does not crack, interfacial delamination can occur.

Since the device package is sensitive to moisture absorption, it is recommended to bake the product before assembly.



Solder Reflow Temperature-Time Profile

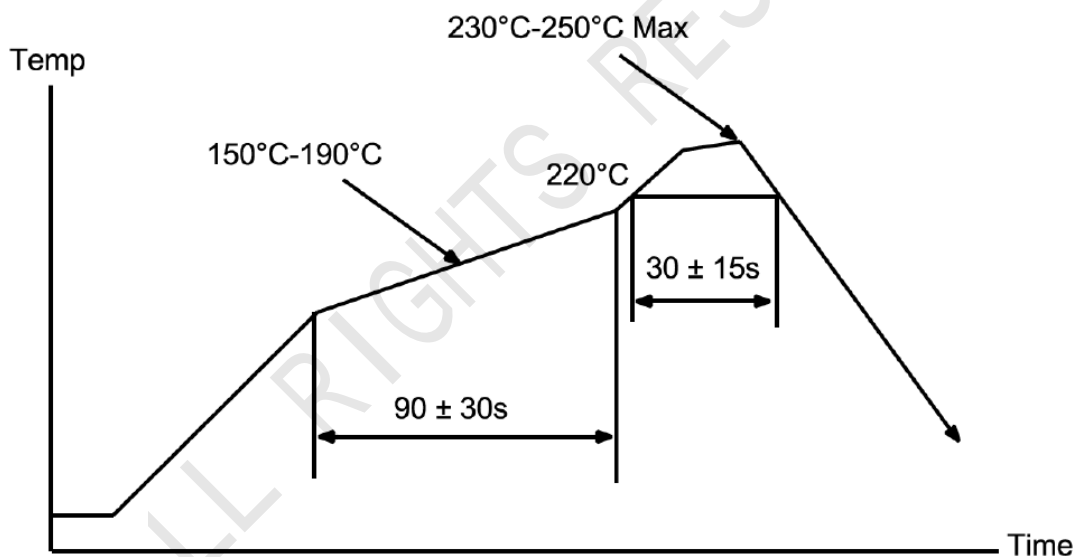

Life Support Applications

Products are not designed for use in life support appliances, devices, or systems where malfunction of these products can reasonably be expected to result in personal injury. Customers using or selling these products for use in such applications do so at their own risk.

Additional Customization

We provide extensive customization, design and manufacturing services to ensure the perfect fit for your product. Our wide selection of modules allows developers to create any number of products. Should you need more information and assistance in integrating this module or developing your product, please contact us.

ABLUE TECHNOLOGY

- Custom Hardware design including Modules, RF and Antenna Design
- Bluetooth Low Energy and Firmware Development
- Mobile Apps for iOS and Android
- Cloud Platform

Trademarks

The Bluetooth® word mark and logos are registered trademarks owned by Bluetooth SIG, Inc., Other trademarks and tradenames are those of their respective owners. ”

Right and Statements

- Reserves the right to make corrections, modifications, and/or improvements to the product and/or its specifications at any time without notice.
- Assumes no liability for the user’s product and/or applications.
- We have a strict and careful check and collation, but can not guarantee this manual without any errors and omissions.
- The contents of this manual by copyright protection laws and regulations, without our prior written authorization of any person shall, in any way to copy the copy or manual, this manual will all or any part of any form in any cable or wireless network transmission, or be compiled and translated into any other format, text or code.

Ordering Information:

Part Number	Description
PTR9818	Bluetooth Low Energy System on Module
PTR9818-EVB	Evaluation boards for module, with key, LED, I/O extend, sock for coin cell battery.